

Window by Allen Kenoyer.

CONTENTS

- Came:D3-D6
 - Brass Came.....D4-D5
 - Copper CameD5-D6
 - Frank Lloyd Wright Shapes.....D6
 - Lead CameD2-3
 - Lead: Crowned w/BrassD3
 - Lead: Crowned w/Brass-Plated ZincD3
 - Lite BrassD4
 - ZincD5-D6
- Copper SheetD7
- Decra-LedD4
- Foil Tape: Copper, Brass & SilverD7
- Reinforcing SystemsD4-D5
 - Re-StripD4
 - Strong Line ReinforcementD4
 - Reinforcing BarsD5
- SolderD6
- Wire:D8
- Wire Benders:D8

NEW SUPPLIES



NO DAYS GLAZE™ NEW!
 No Days Glaze™ is a superior bonding and sealing solution designed for use with a wide range of metal came products including lead, brass, and zinc. Available in six different widths in three colors (Black, Pewter, and Clear). 27' total on each roll (9 strips, 3' each).

Cat. No.	Description
90030	Black 9/64" (3.56mm)
90031	Pewter 9/64" (3.56mm)
90032	Clear 9/64" (3.56mm)
90033	Black 5/32" (3.96mm)
90034	Pewter 5/32" (3.96mm)
90035	Clear 5/32" (3.96mm)
90036	Black 3/16" (4.78mm)
90037	Pewter 3/16" (4.78mm)
90038	Clear 3/16" (4.78mm)

Cat. No.	Description
90039	Black 13/64" (5.16mm)
9003910	Pewter 13/64" (5.16mm)
9003911	Clear 13/64" (5.16mm)
9003912	Black 7/32" (5.56mm)
9003913	Pewter 7/32" (5.56mm)
9003914	Clear 7/32" (5.56mm)
9003915	Black 1/4" (6.35mm)
9003916	Pewter 1/4" (6.35mm)
9003917	Clear 1/4" (6.35mm)
9003918	Heat Gun



NO DAYS GLAZE™ GAUGE KIT NEW!
Cat. No. 900319
 Six Gauge Strips representing the six No Days Glaze™ channel widths. Simply place the gauge strip into the metal came channel to determine what size of NO DAYS Glaze™ is required.

Black Backed Copper Foil Sheet
 Page D7

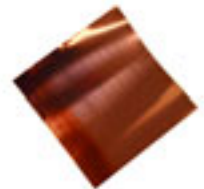

44 lb. Box Lead Came
 Page D2



Quality Lead Came

Came is arranged in order of shape then size.

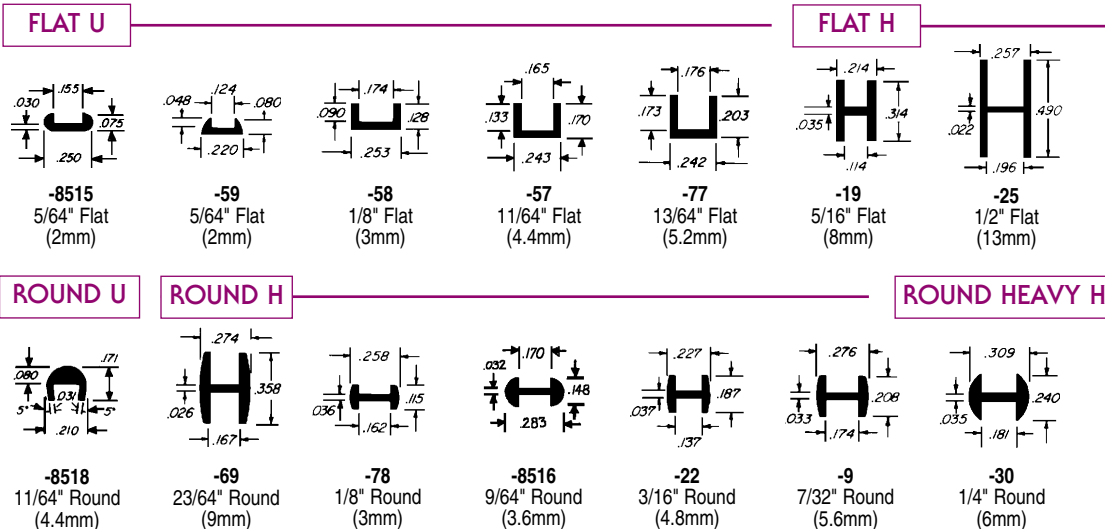

TOP QUALITY LEAD CAME

Our came contains no reclaimed lead, so it is almost 100% chemically pure. As a result, the came is a bright silver color and not the usual dull grey. It solders easily without wire brushing.

Drawings are actual size. Dimensions of lead came are in cross section views. Shape and illustrations are for came on spools and in boxes of 120 lbs. and 44 lbs. (*Lead came is only available on reels and in 44 lb. and 120 lb. boxes. 120 lb. boxes must be shipped by truck.*)

UNIQUE PACKING METHOD

FOR 6 ft. (1.83m) LENGTHS OF LEAD CAME

Our lead came is far superior to any other produced. Our unique packing methods account for much of the difference. Each box is completely lined with polyethylene so that moisture cannot migrate from the wooden box onto the surface of the lead causing it to tarnish. If the liner is folded shut each time some of the comes are removed, the lead is indefinitely protected against tarnishing. All types of lead came are packed in straight, untwisted, neat and even rows. Each layer of lead is interleaved with special paper which will not absorb moisture. This also prevents layers of lead from becoming entangled. Strips are packed in wooden cases and strapped with steel bands to prevent bursting.

BY THE BOX

No stretch lead in the mini-dense pack.
Strips are 47" (1194mm) long.
Net weight is between 44 and 45 lbs.

LEAD CAME 44 LB. BOX

Cat. No. 4030-8518
Round U 11/64" lead came available in 44 lb. boxes.
556 47" long (1194mm) strips per box.



6 ft (1.83m) lengths—By the Box

Came Cat. No.	Shape	*Standard	Metric	Strips per Box
4000-8515B	Flat U	5/64"	2.0mm	495
4013-8518B	Round U	11/64"	4.4mm	230
4006-78B	Round H	1/8"	3.0mm	300
4016-8516B	Round H	9/64"	3.6mm	240
4007-22B	Round H	3/16"	4.8mm	225
4008-9B	Round H	7/32"	5.6mm	190
4009-30B	Rd. Heavy H	1/4"	6.0mm	133

47" (1194mm) lengths—By the Box

Came Cat. No.	Shape	*Standard	Length per Box	
			Standard	Metric
4030-59	Flat U	5/64"	880 ft.	268m
4030-8515	Flat U	5/64"	1117 ft.	340m
4030-58	Flat U	1/8"	572 ft.	174m
4030-57	Flat U	11/64"	513 ft.	156m
4030-77	Flat U	13/64"	548 ft.	167m
4030-25	Flat H	1/12"	266 ft.	81m
4030-19	Flat H	5/16"	337 ft.	103m
4030-78	Round H	1/8"	666 ft.	203m
4030-22	Round H	3/16"	482 ft.	147m
4030-9	Round H	7/32"	425 ft.	130m
4030-30	Round H	1/4"	279 ft.	85m
4030-69	Round H	23/64"	253 ft.	77m
4030-8518	Round C	11/64"	556 ft.	169m



CAME DEFINITIONS					
FACE WIDTH		CHANNEL WIDTH		HEART	
U Came	H Came	U Came	H Came	U Came	H Came

13 shapes are available in convenient boxes and on spools. Six-foot came lengths are offered in 33 lb. (15kg) and 50 lb. (22.7kg) boxes. Continuous lengths of came on 24 lb. (10.9kg) spools are economical and convenient. Cut off needed lengths with no wasted short ends. The lead alloy contains .75 to 1% antimony for added rigidity.

Came is arranged in order of shape then face width.

-401 Face 3/32" (.084) Channel 1/8" (.125) Heart 1/32" (.032)	-602 Face 1/8" (.128) Channel 5/32" (.156) Heart 1/32" (.032)	-702 Face 1/4" (.250) Channel 5/32" (.156) Heart 1/32" (.032)	-20 Face 3/16" (.198) Channel 5/32" (.156) Heart 3/32" (.094)
-204 Face 5/16" (.309) Channel 13/64" (.200) Heart 1/32" (.032)	-209 Face 1/2" (.500) Channel 13/64" (.200) Heart 1/32" (.032)	-315 Face 3/32" (.100) Channel 5/32" (.156) Heart 1/32" (.032)	-103 Face 3/16" (.185) Channel 9/64" (.140) Heart 1/32" (.032)
-23 Face 3/16" (.198) Channel 13/64" (.200) Heart 1/32" (.032)	-564 Face 13/64" (.219) Channel 3/16" (.188) Heart 1/32" (.032)	-313 Face 9/64" (.141) Channel 13/64" (.203) Heart 1/32" (.032)	-96 Face 1/4" (.250) Channel 3/16" (.188) Heart 1/32" (.032)
	NOTE: Actual dimensions are in decimals. All English fractions are approximate. Profiles are shown as close as possible to the actual shape and size of the lead.		
-65 Face 7/32" (.219) Channel 3/16" (.200) Heart 1/32" (.032)			

PREMIER LEAD CAME ON SPOOLS							
Came Cat. No.	Shape	Face Width		Spool Weight		Length (approx.)	
		Standard	Metric	Standard	Metric	Standard	Metric
4062-401	Flat U	3/32"	2.4mm	24 lbs.	10.9kg	417 ft.	127.1m
4062-602	Flat U	1/8"	3.0mm	24 lbs.	10.9kg	282 ft.	85.9m
4062-20	Round U	3/16"	4.8mm	24 lbs.	10.9kg	219 ft.	66.7m
4062-315	Round H	3/32"	2.4mm	24 lbs.	10.9kg	328 ft.	99.5m
4062-103	Round H	3/16"	4.8mm	24 lbs.	10.9kg	224 ft.	68.3m
4062-23	Round H	3/16"	4.8mm	24 lbs.	10.9kg	235 ft.	71.6m
4062-564	Round H	13/64"	5mm	24 lbs.	10.9kg	202 ft.	61.5m

PREMIER LEAD CAME IN STRIPS						
Came Cat. No.	Shape	Face Width		Weight		Strips Per Box
		Standard	Metric	Standard	Metric	
4061-401	Flat U	3/32"	2.4mm	50 lbs.	22.7kg	144
4061-602	Flat U	1/8"	3.0mm	50 lbs.	22.7kg	98
4060-702	Flat U	1/4"	6.0mm	33 lbs.	15.0kg	44
4060-204	Flat H	5/16"	8.0mm	33 lbs.	15.0kg	35
4061-209	Flat H	1/2"	13mm	50 lbs.	22.7kg	45
4060-20	Round U	3/16"	4.8mm	33 lbs.	15.0kg	50
4061-315	Round H	3/32"	2.4mm	50 lbs.	22.7kg	114
4061-103	Round H	3/16"	4.8mm	50 lbs.	22.7kg	78
4061-23	Round H	3/16"	4.8mm	50 lbs.	22.7kg	81
4061-564	Round H	13/64"	5mm	50 lbs.	22.7kg	70
4061-313	Round H	9/64"	5.5mm	50 lbs.	22.7kg	107
4061-96	Round H	1/4"	6mm	50 lbs.	22.7kg	67
4060-65	Colonial H	7/32"	.219mm	33 lbs.	15.0kg	35

BRASS CROWNED LEAD CAME

Adds strength and gives an elegant finish to leaded panels. Cuts easily with a hacksaw. Strips are 6.6 ft. (2m) long. Solder connections can be touched up with brass paint: Deco Color Paint Marker - Cat. No. 7254G (on pg. F10).

BRASS PLATED ZINC CROWNED LEAD CAME

Easy to bend H lead came has been crowned with zinc, then plated with brass. This came is as easy to bend as zinc came and does not crimp at the corners when bent. Available in boxes of fifty 6' long strips.

U - Flat	H - Flat	H-Round	H-Round	H -1/2 Rd.
40317	40310 40316 40312 40313	40318	40001	40311 40314 40315

BRASS CROWNED & ZINC CROWNED LEAD CAME				
Cat. No.	Shape	Face Width x Channel Width		Brass Surfaces
		Standard	Metric	
40317	Flat U	1/4" x 5/32"	6 x 4mm	Single Brass
40310	Flat H	5/32" x 5/32"	4 x 4mm	Double Brass
40312*	Flat H	13/64" x 5/32"	5 x 4mm	Soft Double Brass*
40313	Flat H	13/64" x 5/32"	5 x 4mm	Double Brass
40316	Flat H	9/32" x 5/32"	7 x 4mm	Double Brass
40001	Round H	13/64" x 9/64"	5 x 3mm	Brss Pltd./Zinc Crwnd
40318	Round H	3/16" x 3/16"	5 x 5mm	Double Brass
40311	Half-Rd. H	13/64" x 5/32"	5 x 4mm	Double Brass
40314	Half-Rd. H	1/4" x 5/32"	6 x 4mm	Double Brass
40315*	Half-Rd. H	1/4" x 5/32"	6 x 4mm	Soft Double Brass*

***SOFT - REPRESENTS A BRASS-ELECTROPLATED ZINC STRIP ROLLFORMED OVER A LEAD PROFILE.** These strips are highly polished and have a vulnerable, unprotected surface (untreated by lacquer finishes to prevent corrosion). Manufacturers and distributors cannot be held liable for the effects of corrosion on these products. When using these products, wipe off all fluxes immediately and limit exposure to outside elements by double or triple-glazing finished panels. **Case quantity 50 pieces; except 40 pieces for #40314-40317.**



Lead & Brass Came

LITE BRASS H CHANNELS

Lighter gauge metal with the same high quality standards. Easier to bend and shape than regular brass channels, giving more design control. 6 ft. (1.8m) lengths; 25 lbs. (11.3kg) per box.

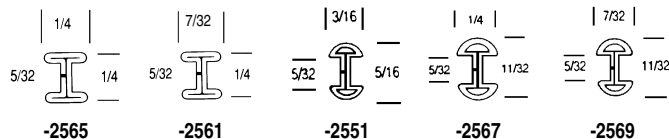

Lite Brass H Channels					
Cat. No.	Shape	Dimensions		Length per Box	
		Standard	Metric	Standard	Metric
4157-2561	Flat H	7/32"	5.5mm	582 ft.	177m
4158-2551	Round H	3/16"	4.8mm	546 ft.	166m
4159-2567	Round H	1/4"	6.3mm	438 ft.	134m
4160-2569	Round H	7/32"	5.5mm	504 ft.	154m
4161-2565	Flat H	1/4"	6.3mm	450 ft.	137m

Add "B" to the end of catalog numbers to purchase by the box.



DECRA-LED

SELF-ADHESIVE STRIP LEAD - Cat. No. 4018-___

Converts plain glass into attractive leaded windows by applying adhesive backed lead strips to either or both sides. Pliable single strand self-adhesive strip lead. Resists long-term weathering. Used for practical or decorative purposes on windows, cabinets or doors, commercially or in homes, churches, etc. Available in 3 widths: 1/8", 1/4" and 3/8".



ANTIQUE BRASS SELF-ADHESIVE STRIP - Cat. No. 40182BR

33 ft. (10m) coil; 1/4" (6mm) width. Identical to the original Decra-Led, but with an antique brass finish. Brass impregnate hardens the brass metal slightly.

BRIGHT BRASS SELF-ADHESIVE STRIP - Cat. No. 40184BR

165 ft. (50m) coil; 1/4" (6mm) width. Identical to the original Decra-Led, but with a bright brass finish. Brass impregnate hardens the brass metal slightly.

Cat. No.	Width		Finish	Length		Pkg. Unit
	Std.	Metric		Std.	Metric	
40181	1/8"	3mm	Lead Self-Stick	66 ft.	20m	Coil
40182	1/4"	6mm	Lead Self-Stick	33 ft.	10m	Coil
40183	3/8"	9mm	Lead Self-Stick	33 ft.	10m	Coil
40182R	1/4"	6mm	Lead Self-Stick	165 ft.	50m	Reel
40183R	3/8"	9mm	Lead Self-Stick	165 ft.	50m	Reel
40182BR	1/4"	6mm	Brass Self-Stick	33 ft.	10m	Coil
40184BR	1/4"	6mm	Brass Self-Stick	165 ft.	50m	Reel



REINFORCING SYSTEMS

RE-STRIP - Cat. No. 4205-___

A reinforcing system for copper foiled projects. Pure copper is placed between foiled glass pieces. The pieces and strip are joined with solder for a rigid unnoticeable joint. .011" (.3mm) thick; approximates glass thickness. Can be bent to a sharp angle.

STRONG LINE REINFORCEMENT - Cat. No. 4206

Fits well in all lead channels and has greater strength due to steel over copper, which safely eliminates or reduces the number of external rebars normally needed for a project. 25 ft. (7.6m) of .020 x .114" (.5mm x 3mm).



Cat. No.	Description	Roll Size	
		Standard	Metric
4205-25	Re-Strip System	25 ft.	7.6m
4205-100	Re-Strip System	100 ft.	30.5m
4206	Strong Line Reinforcement	25 ft.	7.6m



REINFORCING BARS

Steel rebar is suitable for straight lines, mild curves or angles.

CHICAGO METALLIC

ZINC U-SHAPE AND H-SHAPE

Zinc is available in rigid channel 6 ft. (1.83m) lengths, making it easier to handle for studio work or resale. Boxes do not exceed 45 lbs., making them suitable for UPS shipment.

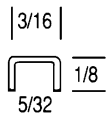

4106-2101

3/16" (48mm) U
5/32" (4mm) Channel

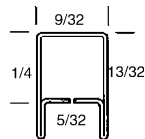

4101-2511

13/32" (10mm) U
5/32" (4mm) Channel

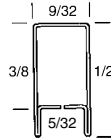

4102-2522

1/2" (12.7mm) U
5/32" (4mm) Channel

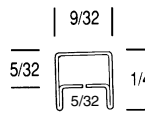

4100-2501

1/4" (6mm) U
5/32" (4mm) Channel

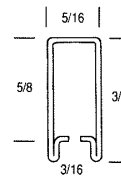

4103-2526

3/4" (19mm) U
3/16" (4.8mm) Channel

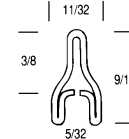

4104-2534

9/16" (14mm) Wishbone
5/32" (4mm) Channel

4151-2101, 4150-2101
Brass, Copper

4155-2501, 4150-2501
Brass, Copper

4153-2511, 4150-2511
Brass, Copper

4154-2522, 4150-2522
Brass, Copper

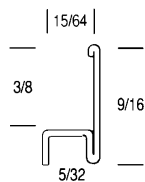

4105-2259

9/16" (14mm) Flanged
5/32" (4mm) Channel

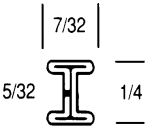

4110-2541

3/16" (4.8mm) H
5/32" (4mm) Channel

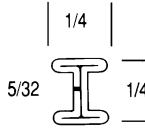

4107-2565

1/4" (6mm) H
5/32" (4mm) Channel

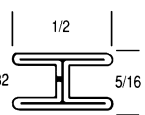

4112-2611

1/2" (12.7mm) H
5/32" (4mm) Channel

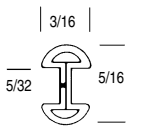

4116-2551

3/16" (4.8mm) Round
5/32" (4mm) Channel

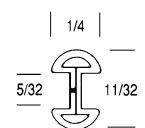

4108-2567

1/4" (6mm) Round
5/32" (4mm) Channel

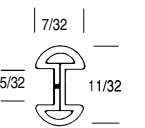

4117-2569

7/32" (5.5mm) - Round
5/32" (4mm) - Channel

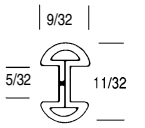

4118-2581

9/32" (7mm) Round
5/32" (4mm) Channel

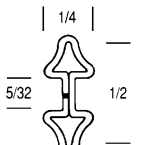

4113-2061

1/4" (6mm) Colonial
5/32" (4mm) Channel

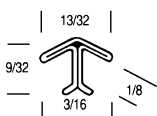

4115-2303

13/32" (10mm) 90° Angle
1/8" (3.2mm) Channel

4156-2303

Brass

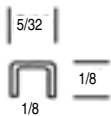

41063

1/8" (3mm) U
1/8" (3mm) Channel

Reinforcing Bars

Cat. No.	Description	Dimensions		NOTE: Add "B" to Cat. No. for a 50 lb. (22.7kg) bundle.
		Standard	Metric	
4200	Steel Pretinned	3/8 x 1/8"	10 x 3mm	4200B - 315 ft. (96m) per bundle.
4202	Steel Pretinned	1/2 x 1/8"	13 x 3mm	4202B - 235 ft. (71.6m) per bundle.
4203	Steel Pretinned	1/4 x 1/8"	6 x 3mm	4203B - 504 ft. (154m) per bundle.

Note: Add B to Cat. No. to purchase a full box.

While quantities may be mixed, box prices apply only to an unbroken box.

Zinc U-Shape and H-Shape

Cat. No.	Came Shape	Dimensions		Style	Weight per Box		Length per Box	
		Std.	Metric		Std.	Metric	Std.	Metric
4106-2101	U	1/8"	3.0mm	Flat	40 lbs.	18kg	1920 ft.	585.2m
4100-2501	U	1/4"	6.0mm	Flat	40 lbs.	18kg	760 ft.	231.6m
4101-2511	U	13/32"	10.0mm	Flat	35 lbs.	15.9kg	451 ft.	137.5m
4102-2522	U	1/2"	12.7mm	Flat	35 lbs.	15.9kg	360 ft.	109.7m
4103-2526	U	3/4"	19.0mm	Flat	30 lbs.	13.6kg	225 ft.	68.6m
4104-2534	U	9/16"	14.0mm	Wishbone	35 lbs.	15.9kg	409 ft.	124.7m
4105-2259	U	9/16"	14.0mm	Flanged	40 lbs.	18kg	644 ft.	196.3m
4110-2541	H	3/16"	4.8mm	Flat	40 lbs.	18kg	1011 ft.	308.1m
4114-2561	H	7/32"	5.5mm	Flat	40 lbs.	18kg	932 ft.	284.0m
4107-2565	H	1/4"	6.0mm	Flat	40 lbs.	18kg	840 ft.	256.0m
4111-2591	H	3/8"	9.5mm	Flat	40 lbs.	18kg	480 ft.	146.3m
4112-2611	H	1/2"	12.7mm	Flat	40 lbs.	18kg	368 ft.	112.1m
4116-2551	H	3/16"	4.8mm	Round	40 lbs.	18kg	784 ft.	238.9m
4108-2567	H	1/4"	6.0mm	Round	40 lbs.	18kg	632 ft.	192.6m
4117-2569	H	7/32"	5.5mm	Round	40 lbs.	18kg	680 ft.	207.3m
4118-2581	H	9/32"	7.0mm	Round	35 lbs.	15.9kg	626 ft.	190.8m
4113-2061	H	1/4"	6.0mm	Colonial	30 lbs.	13.6kg	360 ft.	109.7m
4115-2303	H	13/32"	10.0mm	90° Angle	40 lbs.	18kg	540 ft.	164.6m

Brass or Copper U-Shape

Cat. No.	Came Shape	Dimensions		Metal	Weight per Box		Length per Box	
		Standard	Metric		Std.	Metric	Std.	Metric
41063	U	1/8"	3.1mm	Brass	40 lbs.	18kg	1555 ft.	473.9m
4151-2101	U	1/8"	3.1mm	Brass	40 lbs.	18kg	1555 ft.	473.9m
4155-2501	U	1/4"	6.0mm	Brass	40 lbs.	18kg	616 ft.	187.7m
4153-2511	U	13/32"	10mm	Brass	35 lbs.	15.9kg	365 ft.	111.2m
4154-2522	U	1/2"	12.7mm	Brass	35 lbs.	15.9kg	292 ft.	89.0m
4156-2303	U	13/32"	10mm	Brass 90°	40 lbs.	18kg	437 ft.	133.1m
4150-2101	U	1/8"	5.5mm	Copper	40 lbs.	18kg	1440 ft.	438.9m
4150-2501	U	1/4"	6.0mm	Copper	35 lbs.	15.9kg	498 ft.	151.8m
4150-2511	U	13/32"	10mm	Copper	40 lbs.	18kg	387 ft.	117.9m
4150-2522	U	1/2"	12.7mm	Copper	35 lbs.	15.9kg	270 ft.	82.3m



Copper & Zinc Came / Solder

CHICAGO METALLIC ZINC and COPPER CAME

For use with derivations of Frank Lloyd Wright Patterns.
Came illustrations are approximate to true size.

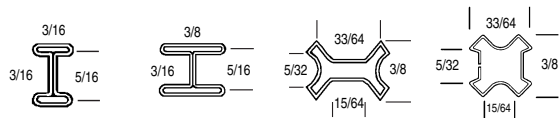

2542 3/16" x 3/16" (4.8 x 4.8mm)
2592 3/8" x 3/16" (9.5 x 4.8mm)
2700 33/64" x 5/32" (13 x 4mm)
2702 11/32" x 3/16" (8.7 x 4.8mm)

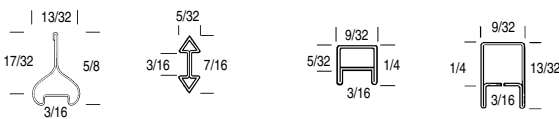

2706 13/32" x 3/16" (10 x 4.8mm)
2707 5/32" x 3/16" (4 x 4.8mm)
2502* 1/4" x 3/16" (6.3 x 4.8mm)
2512* 13/32" x 3/16" (10 x 4.8mm)

CANFIELD SOLDER

50/50 SOLDER

Cat. No. 4300-501

50% tin, 50% lead. 1/8" wire. Melting point of 421°F (216°C). Primarily for copper foil soldering. Available in 1, 5 and 25 lb. spools.

60/40 SOLDER

Cat. No. 4300-601

60% tin, 40% lead. 1/8" wire. Melting point of 374°F (190°C). Primarily for lead came soldering. Available in 1, 5 and 25 lb. spools.

QUIK SET™ SOLDER

Cat. No. 4300QS

BEADS INSTANTLY! Makes a perfect bead in one pass of the iron. The bead sets up with a silvery shine. 1 lb. spool. Melting point 400°F (204°C)

ULTIMATE SOLDER

Cat. No. 4300-ULT

More than 62% tin, the balance is lead. Melting point of 356°F (180°C). Because of instant freeze, this is primarily for decorative soldering. 1 lb. spool.

LEAD-FREE SOLDER PEWTER FINISH

Cat. No. 4303

A unique solder that renders a lightweight, yet strong product with lovely satin finish seams resembling pewter. This lead-free solder is 100% safe for jewelry, skin contact and food receptacle applications. It has the penetration, solderability, and capillary actions of 50/50 and maintains a beautiful pewter finish. 100 watt iron suggested. Melting temperature: 418°F to 440°F (214°C to 227°C).

GLASS PRO™ SOLDER



Cat. No. 4302-501

Glass Pro™ 50 (1 lb.) 50% tin, 50% lead. 1/8" (3mm) wire. Melting point of 421°F (216°C).

Cat. No. 4302-601

Glass Pro™ 60 (1 lb.) 60% tin, 40% lead. 1/8" (3mm) wire. Melting point of 374°F (190°C).

Zinc and Copper Came

Cat. No.	Came Shape	Dimensions		Weight per Box		Length per Box	
		Width	Channel	Standard	Metric	Std.	Metric
ZINC CAME:							
4109-2542	H	3/16"	3/16"	25 lbs.	11.3kg	615 ft.	187m
4109-2592	H	3/8"	3/16"	25 lbs.	11.3kg	287 ft.	87m
4109-2700	H	33/64"	5/32"	25 lbs.	11.3kg	300 ft.	91m
4109-2702	H	11/32"	3/16"	25 lbs.	11.3kg	350 ft.	107m
4109-2706	U	13/32"	3/16"	25 lbs.	11.3kg	252 ft.	77m
4109-2707	H	5/32"	3/16"	25 lbs.	11.3kg	625 ft.	190m
4109-2502*	U	1/4"	3/16"	25 lbs.	11.3kg	475 ft.	145m
4109-2512*	U	13/32"	3/16"	25 lbs.	11.3kg	322 ft.	98m
COPPER CAME:							
4119-2542	H	3/16"	3/16"	25 lbs.	11.3kg	474 ft.	144m
4119-2592	H	3/8"	3/16"	25 lbs.	11.3kg	215 ft.	66m
4119-2700	H	33/64"	15/64"	25 lbs.	11.3kg	225 ft.	69m
4119-2702	H	11/32"	3/16"	25 lbs.	11.3kg	262 ft.	80m
4119-2706	U	13/32"	3/16"	25 lbs.	11.3kg	189 ft.	58m
4119-2707	H	5/32"	3/16"	25 lbs.	11.3kg	468 ft.	143m
4119-2502*	U	1/4"	3/16"	25 lbs.	11.3kg	356 ft.	109m
4119-2512*	U	13/32"	3/16"	25 lbs.	11.3kg	241 ft.	73m

*U Channel dimension is the height.

Canfield and Glasspro Solders

Cat. No.	Description Brand	Spool Size	Composition		Wire Size		Melting Pt.	
			Tin	Lead	Inch	Metric	°F	°C
4300-501	Canfield 50/50*	1 lb.	50%	50%	1/8"	3mm	421°	216°
4300-505	Canfield 50/50	5 lbs.	50%	50%	1/8"	3mm	421°	216°
4300-5025	Canfield 50/50	25 lbs.	50%	50%	1/8"	3mm	421°	216°
4300-601	Canfield 60/40*	1 lb.	60%	40%	1/8"	3mm	374°	190°
4300-605	Canfield 60/40	5 lbs.	60%	40%	1/8"	3mm	374°	190°
4300-6025	Canfield 60/40	25 lbs.	60%	40%	1/8"	3mm	374°	190°
4300-QS	Canfield Quik-Set™*	1 lb.	Alloy between 50/50 & 60/40		1/8"	3mm	400°	204°
4300-ULT	Canfield Ultimate*	1 lb.	62%	38%	1/8"	3mm	356°	180°
4303	Canfield Lead-Free*	1 lb.	95%	----	1/8"	3mm	430°	221°
4302-501	Glasspro™ 50*	1 lb.	50%	50%	1/8"	3mm	421°	216°
4302-601	Glasspro™ 60*	1 lb.	60%	40%	1.8"	3mm	374°	190°

*Fifty 1 lb. spools per carton.

CANFIELD SOLDER



GLASS PRO™ SOLDER



VENTURE



BLACK BACK COPPER FOIL TAPE

Developed for use on clear glass and mirrors. When the finished project is coated with black patina, the adhesive side is not evident as it would be with regular foil.

- Thickness:** 1.25 mil
Roll Dimensions: .00125" x 36 yds. (.03mm x 33m)
Width:
- Cat. No. 4415-316** 3/16" (4.8mm)
 - Cat. No. 4415-732** 7/32" (5.5mm)
 - Cat. No. 4415-140** 1/4" (6.4mm)
 - Cat. No. 4415-516** 5/16" (7.9mm)

"MASTER" BRAND FOIL

Specially formulated Acrylic Adhesive System is soft, has much higher quick stick and is stronger than the foil. Greater conformability and superior adhesion. Ductile copper on heat resistant acrylic adhesive. Precision slit to uniform width.



SHEET COPPER FOIL

Cat. No. 44071

Sheet Size: 12" x 12" (305 x 305mm). Adhesive backed.

Cat. No. 4409

Roll Size: 12" (305mm) x 36 yd. (33m). Ideally suited for filigree overlays or special creative effects. Adhesive backed, 1.25 mil thick. Packaged individually in a poly bag with a punched header.

COPPER SHEET - Cat. No. 44190

Individually packaged copper sheet without adhesive backing. Each sheet is 6" x 8" (152 x 203mm) and .005" (.127mm) thick. Excellent for decorative projects requiring copper shapes to supplement art glass constructions. Easy to apply patina to copper surface.



COPPER FOIL SHEET, BLACK BACKED - Cat. No. 44191

12 x 12" x .125" (305 x 305 x 3mm) thick. Individually packed with adhesive back.



BRASS FOIL TAPE - Cat. No. 4417-___

Developed for those projects which need to be bound with brass tape, yet need not be soldered overall. Solder at the seam can be colored with a brass marker (Cat. No. 7254G) found on pg. F10.

SILVERED COPPER FOIL TAPE

Cat. No. 4412, 4413, 4414 - Both sides plated

Cat. No. 4418 - Single side plated

No more visible copper on internal lip. The copper foil is heavily plated to match solder. Accepts solder well, unaffected by flux. Conforms to curves or corners. (Recommended for clear and mirrored glass.)

"NEW WAVE" COPPER FOIL TAPE

Cat. No. 4416

Designed for special projects, lamp borders, fan lamps, nite lights, etc. This copper foil has one scalloped edge with the same excellent quality of Master Foil by Venture.

- Length:** 36 yds. (33m)
Width: 5/16" (7.9mm)
Thickness: 1.5 mil
Contour Width: 3/32" (2.4mm)



"NEW WAVE" SILVERED COPPER FOIL TAPE

Cat. No. 44161775

- Length:** 18 yds. (16.5m)
Width: 5/16" (7.9mm)
Thickness: 1.5 mil
Contour Width: 3/32" (2.4mm)



"NEW WAVE" BLACK BACK COPPER FOIL TAPE

Cat. No. 44161773

- Length:** 36 yds. (33m)
Width: 5/16" (7.9mm)
Thickness: 1.5 mil
Contour Width: 3/32" (2.4mm)

Venture Master Brand Foil

Cat. No.	Thick.	Roll Dimensions		Width	
		Standard	Metric	Std.	Metric
4410	1 mil	.001" x 36 yd.	.025mm x 33m	5/32"	4.0mm
4400	1 mil	.001" x 36 yd.	.025mm x 33m	3/16"	4.8mm
4401	1 mil	.001" x 36 yd.	.025mm x 33m	7/32"	5.5mm
4402	1 mil	.001" x 36 yd.	.025mm x 33m	1/4"	6.4mm
4403	1 mil	.001" x 36 yd.	.025mm x 33m	5/16"	7.9mm
4404	1 mil	.001" x 36 yd.	.025mm x 33m	3/8"	9.5mm
4405	1 mil	.001" x 36 yd.	.025mm x 33m	1/2"	12.7mm
4400015	1.5 mil	.0015" x 36 yd.	.040mm x 33m	3/16"	4.8mm
4401015	1.5 mil	.0015" x 36 yd.	.040mm x 33m	7/32"	5.5mm
4402015	1.5 mil	.0015" x 36 yd.	.040mm x 33m	1/4"	6.4mm
4411	3 mil	.0030" x 36 yd.	.080mm x 33m	3/8"	9.52mm
441110	3 mil	.0030" x 10 yd.	.080mm x 9m	3/8"	9.52mm

Venture Brass and Silver Copper Foil Tape

Cat. No.	Material	Roll Dimensions		Width	
		Standard	Metric	Std.	Metric
4417-316	.001" Brass	.001" x 36 yd.	.025mm x 33m	3/16"	4.8mm
4417-732	.001" Brass	.001" x 36 yd.	.025mm x 33m	7/32"	5.5mm
4417-140	.001" Brass	.001" x 36 yd.	.025mm x 33m	1/4"	6.4mm
4412	.0015" Silver (2)*	.001" x 36 yd.	.025mm x 33m	3/16"	4.8mm
4413	.0015" Silver (2)*	.001" x 36 yd.	.025mm x 33m	7/32"	5.5mm
4414	.0015" Silver (2)*	.001" x 36 yd.	.025mm x 33m	1/4"	6.4mm
4418-316	.0015" Silver (1)*	.001" x 36 yd.	.025mm x 33m	3/16"	4.8mm
4418-732	.0015" Silver (1)*	.001" x 36 yd.	.025mm x 33m	7/32"	5.5mm
4418-140	.0015" Silver (1)*	.001" x 36 yd.	.025mm x 33m	1/4"	6.4mm

(2)* - Silver plated over copper on two sides

(1)* - Silver plated over copper on one side only.

Brite Back Gold Color Tape - Cat. No. 44081

Brite Back Silver Color Tape - Cat. No. 4408

(See page F6)



See chart below for all wire specifications.



BRASS WIRE

Cat. No. 4501 - 16 ga.
Brass, 32 ft. roll (9.75m)

Cat. No. 45001 - 20 ga.
Brass, 79 ft. roll (24m)



TINNED COPPER WIRE

Cat. No. 4520 - ___
4 oz. (113g) spool.

Cat. No. 4521 - ___
1 lb. (454g) spool.
Bright silver. Solders easily to lead, foil or zinc. Soft temper for easy forming.



BRAIDED TINNED COPPER WIRE

Cat. No. 4525
100 ft. (30m) roll.
1/8" (3mm) wide, approximately .020" (5mm) thick. Excellent for borders and trim. Solders well.



HIGH TEMP WIRE

Cat. No. 450417
10 ft. (3m) roll.
.045" (1.1mm) diameter, 17 ga. wire. General purpose wire. Remains strong in extreme heat from kiln firings and withstands high temperatures for long periods.



HIGH TEMP STAMEN WIRE

Cat. No. 450424
10 ft. (3m) long, .020" (0.5mm) diam., 24 ga. wire.



COPPER WIRE

Cat. No. 4502 -
1 lb. (454g) spool.

Cat. No. 4503 -
4 oz. (113g) spool.
Pure copper wire for fusing projects. Solders well to lead, zinc or copper foil.



TWISTED TINNED COPPER WIRE

Cat. No. 45261 - 25 ft. roll (20 ga).
Cat. No. 45262 - 100 ft. roll (20 ga).
Cat. No. 45263 - 25 ft. roll (14 ga).
Cat. No. 45264 - 100 ft. roll (14 ga).
Tightly twisted pair of tinned copper wire in two gauge sizes and two convenient spool lengths.



TWISTED SQUARE BRIGHT BRASS WIRE

Cat. No. 45280
24 ft. Double strand twisted wire. 20 ga.

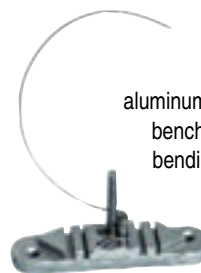

HANDI-BENDER

Cat. No. 24555

Handi-Bender is a rugged cast aluminum bending jig for use on a board, bench or in a vise. It has three steel bending pins. Includes instructions for making basic bends such as centered and off-centered eyes, curves, angles, circles and spirals. Instructions also cover wire straightening, soldering and wire cutting. Diagrams of shapes that can be made with the Handi-Bender are included.



WIRE FORMING PEGBOARD

Cat. No. 24556
A rugged cast aluminum bending pegboard with 16 steel bending pins.

Includes instructions for making basic bends such as centered and off-centered eyes, curves, angles, circles and spirals. Instructions also cover wire straightening, soldering and wire cutting.

WIRE SPECIFICATIONS

Cat. No.	Description	Dimensions*			Weight*		Pkg.	Length	
		Ga.	Std.	Metric	Standard	Metric		Std.	Metric
4502-14	Pure Copper	14	.064"	1.6mm	1 lb.	454g	Spool	80 ft.	24.4m
4502-16	Pure Copper	16	.051"	1.3mm	1 lb.	454g	Spool	126 ft.	38.4m
4502-20	Pure Copper	20	.032"	0.8mm	1 lb.	454g	Spool	315 ft.	96m
4503-14	Pure Copper	14	.064"	1.6mm	4 oz.	113g	Spool	20 ft.	6m
4503-16	Pure Copper	16	.051"	1.3mm	4 oz.	113g	Spool	32 ft.	9.8m
4503-20	Pure Copper	20	.032"	0.8mm	4 oz.	113g	Spool	79 ft.	24m
4501	Brass	16	.051"	1.3mm	-----	-----	Roll	27 ft.	8.2m
45001	Brass	20	.032"	.8mm	-----	-----	Roll	50 ft.	15.2m
4520-14	Tinned Copper	14	.064"	1.6mm	4 oz.	113g	Spool	20 ft.	6m
4520-16	Tinned Copper	16	.051"	1.3mm	4 oz.	113g	Spool	32 ft.	9.8m
4520-18	Tinned Copper	18	.040"	1.0mm	4 oz.	113g	Spool	50 ft.	15.2m
4520-20	Tinned Copper	20	.032"	0.8mm	4 oz.	113g	Spool	79 ft.	24m
4521-14	Tinned Copper	14	.064"	1.6mm	1 lb.	454g	Spool	80 ft.	24.4m
4521-16	Tinned Copper	16	.051"	1.3mm	1 lb.	454g	Spool	128 ft.	39.0m
4521-18	Tinned Copper	18	.040"	1.0mm	1 lb.	454g	Spool	203 ft.	61.9m
4521-20	Tinned Copper	20	.032"	0.8mm	1 lb.	454g	Spool	323 ft.	98.5m
4525	Braided Tinned Copper		.125"	3.2mm	-----	-----	Roll	100 ft.	30.5m
450417	High Temp Wire	17	.045"	1.1mm	-----	-----	Roll	10 ft.	3m
450424	High Temp Wire	24	.020"	.5mm	-----	-----	Roll	10 ft.	3m
45261	Twisted Tinned Copper	20	.032"	0.8mm	2-3/4 oz.	78g	Roll	25 ft.	7.6m
45262	Twisted Tinned Copper	20	.032"	0.8mm	11 oz.	312g	Roll	100 ft.	30.5m
45263	Twisted Tinned Copper	14	.064"	1.6mm	11 oz.	312g	Roll	25 ft.	7.6m
45264	Twisted Tinned Copper	14	.064"	1.6mm	2-3/4 oz.	78g	Roll	100 ft.	30.5m
45280	Twisted Bright Brass	20	.032"	0.8mm	2-3/4 oz.	78g	Coil	24 ft.	7.3m

*Dimensions and weights are approximate.